

DID YOU KNOW?

about our...



**NEW
PRODUCT**

Lifting Swivel Eye Bolt with Key

Approved and certified for lifting.

Can be used in axial or angular loading.

LIFTING SWIVEL EYE BOLT WITH KEY GRADE 100 / POWDER COATED / HEC

Part	Qfind	Size	WLL (Tonne)		Dimensions (mm)				Pack Qty
			0°	90°	A	B	C	T	
ULES10PBDM08	ES10BDM8	M8	0.80	0.30	38	26	45	12	50
ULES10PBDM10	ES10BDM10	M10	1.00	0.40	38	26	45	14	25
ULES10PBDM12	ES10BDM12	M12	2.00	0.80	44	32	54	17	25
ULES10PBDM16	ES10BDM16	M16	4.00	1.50	52	38	64	24	20
ULES10PBDM20	ES10BDM20	M20	6.00	2.30	63	45	79	30	10



Locking key for simple assembly and disassembly

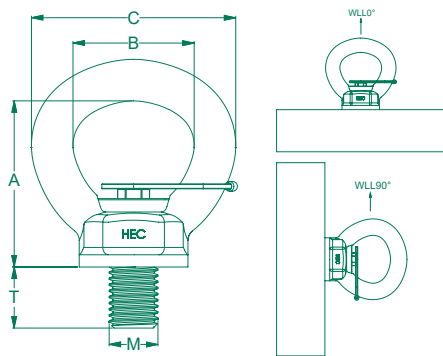

MARKINGS:

- **CE**
(European Conformity)
- **WLL**
(Working Load Limit)
- **Trace Code**
(Linked to certificate online)
- **Size**
- **Manufacturer's mark**



FEATURES

- Swivel load ring for rotation under load
- Suitable for dynamic lifting
- 360° Swivel motions
- Use with Grade 100 lifting components
- Locking key to aid tightening of bolt



You can download this Test Certificate and/or Report from our website:

hobson.com.au

Disclaimer: While every reasonable effort has been made to ensure that this document is correct at the time of printing, Hobson Engineering®, its agencies and employees, disclaim any and all liability to any person in respect of anything or the consequences of anything done or omitted to be done in reliance upon the whole or any part of this document.

Bolt Tension | Anti-Vibration | Product Reliability | Traceability

hobson.com.au QUALITY FASTENERS SINCE 1935

